

HARNISCH COMPANY

Architectural Hardware

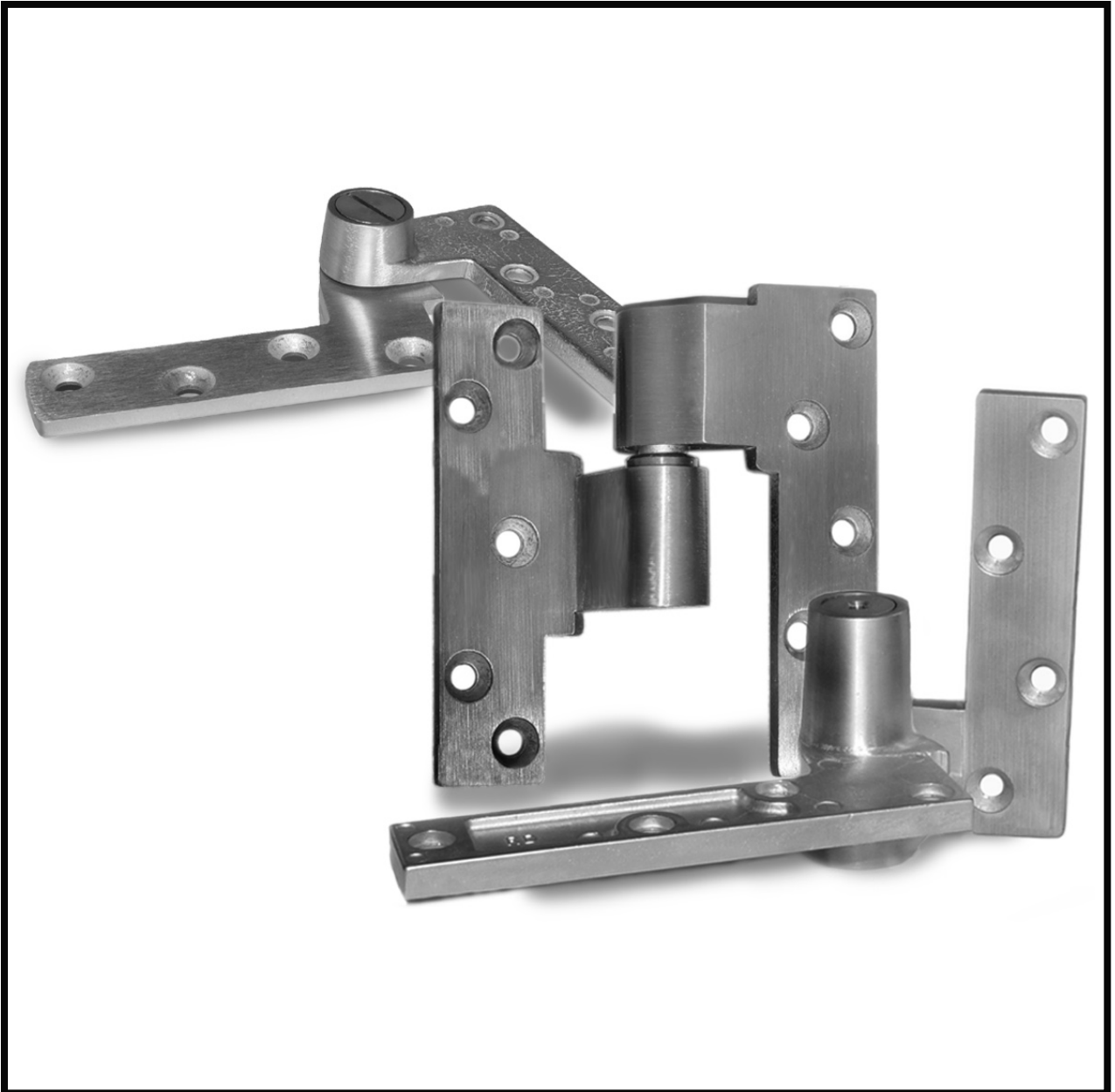

Pivots

**7651 Woodwind Drive
Huntington Beach CA 92647
www.harnisch.net**

**714-841-4486
714-841-9635 fax
800-258-8780 fax**

EMP3 - POWER TRANSFER PIVOT
3/4" OFFSET - FULL MORTISE

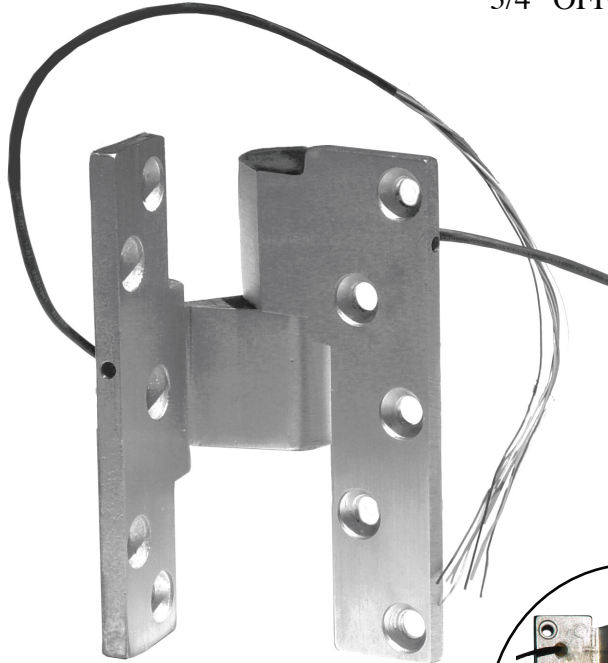

The EMP3 Electrified Intermediate Pivot features FOUR pairs of stranded conductors providing concealed low voltage current transfer.

U.L. Listed wire with TFE Teflon® Insulation #28 AWG with 7/36 stranding. Rated 24 volts maximum, U.L. Style 1371.

Electrical 2 Amps @ 24V DC per pair maximum. 8 Amps maximum utilizing four pairs in a circuit.

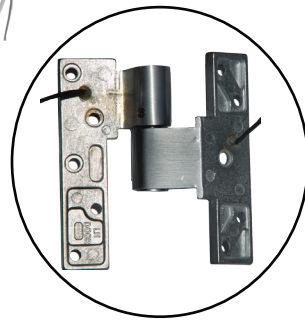

- Non-load bearing.
- Non-separable leaves.
- Specify handing.

MP3 INTERMEDIATE PIVOT - 3/4" OFFSET

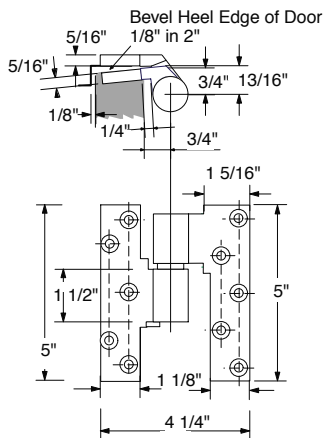

- Interior or exterior doors
- Heavy-duty needle bearing standard
- 3/16" vertical adjustment after installation
- Full mortise, handed
- Non-ferrous material
- Furnished with machine screws
- BHMA/ANSI C07321/3525

MP1 TOP PIVOT - 3/4" OFFSET

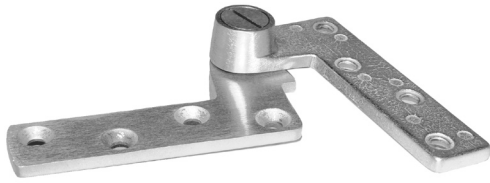

- Interior or exterior doors
- Heavy-duty needle bearing standard
- Full mortise, non-handed

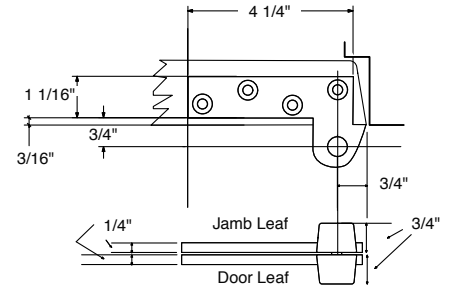

- Non-ferrous material
- Furnished with machine screws

MP4 BOTTOM PIVOT



- Interior or exterior doors
- Weight up to 600 lbs.
- Door width up to 4' 0"

- Heavy-duty needle bearing standard
- 3/4" vertical adjustment w/positive locking feature
- Full mortise, non-handed
- Furnished with machine screws
- BHMA/ANSI C07162/3530A

MP2 BOTTOM PIVOT - 3/4" OFFSET

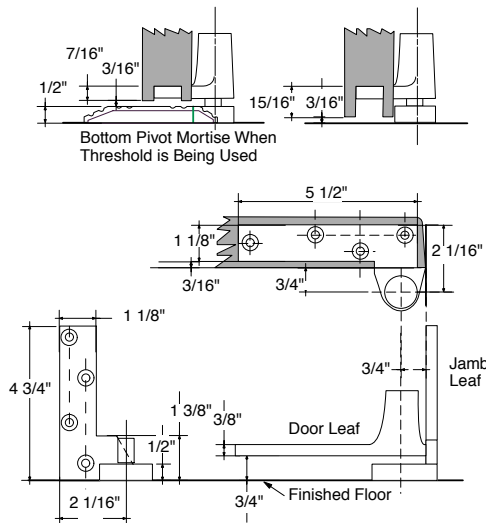

- Interior or exterior doors
- Weight up to 450 lbs.
- Door width up to 4' 0"

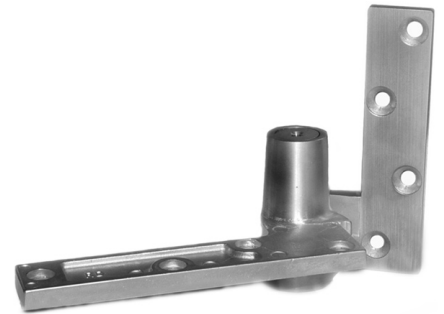

- Heavy-duty needle bearing standard
- 3/16" vertical adjustment after installation
- Full mortise, handed
- Non-ferrous material
- Furnished with machine screws
- BHMA/ANSI C07131/3520

- 3/4" Offset center line from edge of door and face of door.
- Door thickness minimum 1-3/4", bevel 1/8" in 2".

Available in the following standard architectural finishes: US3, US4, US10, US10B, US26, US26D.
Optional finishes and powder-coating available.



Established in 1985, the Harnisch Company is a leading manufacturer of architectural door hardware. We specialize in supplying leading OEM manufacturers throughout North America, Europe, and Asia.

Products include: UL listed flush and surface bolts, handles and push bars, heavy-duty 3/4" offset pivots, overhead holders, wall and floor stops, and roller latches. We manufacture our products to meet or exceed AAMA, BHMA, and ANSI specifications.

Additionally, we produce many types of custom designed, patented, and proprietary products. Our emphasis on quality products is supported by our state of the art equipment and facilities. Tooling capabilities include: forging, investment casting, stamping, bending and extruding. We provide US Code and BHMA finishes. Our anodizing facility yields class one electrolytically deposited finishes that meet or exceed AAMA 611-98 specifications.

